

AIR MOVING MOTOR: 5.7 in. / 144.8 mm. 24 V 3-Stage

MODEL:116515-29

SPECIFICATIONS

Motor Type:	Series Universal
Input Voltage:	24 VDC,
Frequency:	
Fan Diameter:	5.7 in./144.8 mm
No. Fan Stages:	3
Fan System Style:	Bypass
Air Discharge:	Tangential
Operating Temp:	32-104°F/0-40°C
Bearing System:	Ball/Ball
Frame:	Skeleton
Brush Type:	Carbon
Inlet Tube Dia.:	1.5 in.
RFI Choke:	None
Speed:	1

ADDITIONAL FEATURES

Regulatory:	UL Recognized, ,
Comm Bracket:	Aluminum
Fan Bracket:	Plastic
Therm Protect:	None
Insulation Class:	Class A
Added Bearing Prot.:	Air Seal
Fan Shell Coat:	Epoxy
Electrical Conn.:	Lead Wires
Duty Cycle:	Intermittent
Special Feature:	

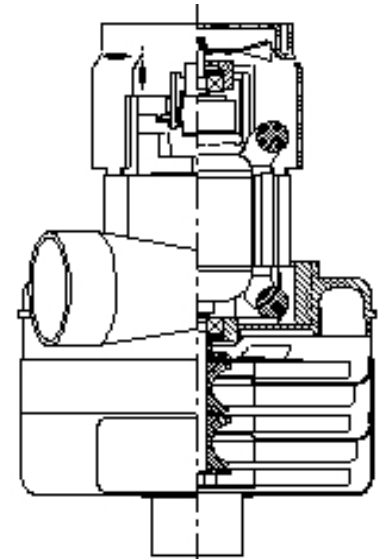

Design Application

Equipment operating in environments requiring separation of working air from motor ventilating air.
 Designed to handle clean,dry, filtered air only

PERFORMANCE

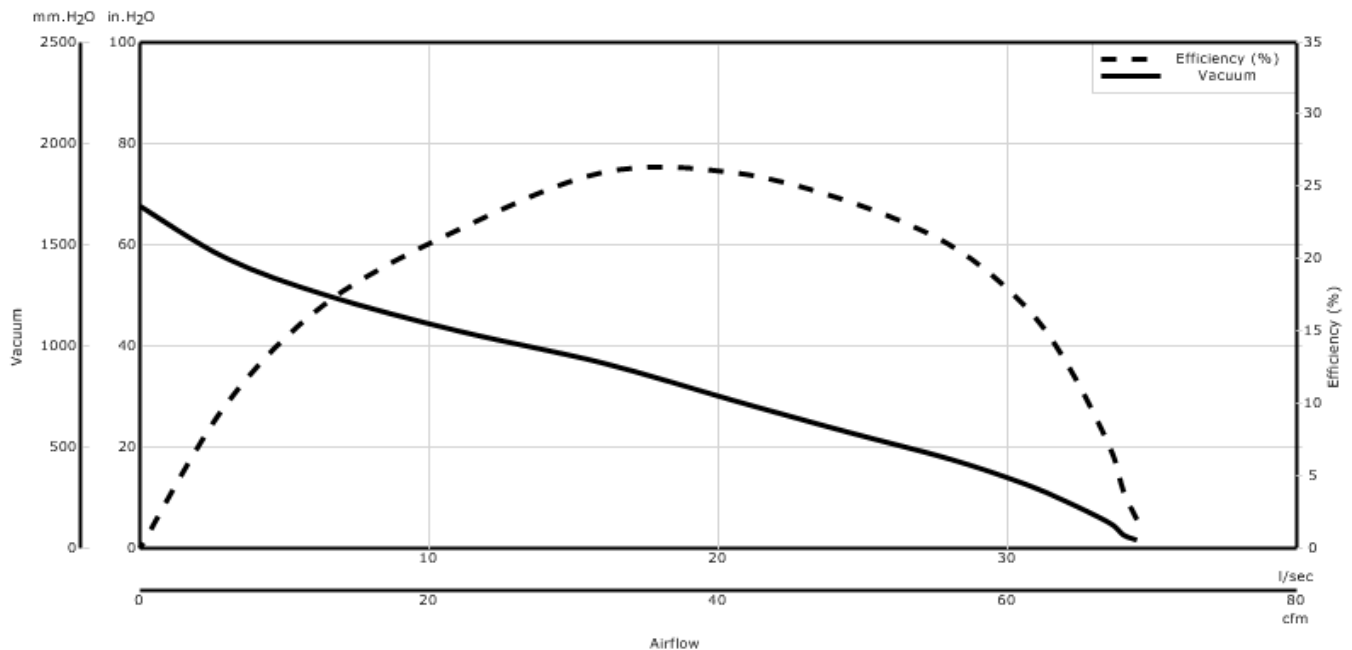

* Data represents performance of a typical motor sampled from a large production quantity. Individual motor data may vary, due to normal manufacturing variations."

Data shown is measured at regulated nominal voltage and normalized to standard atmospheric pressure and temperature.

ENGLISH

Orifice (inches)	Amps	Watts (In)	RPM	Vac (In. H2O)	Flow (CFM)	Air Watts
2.000	20.90	535	12667	1.7	69.0	13
1.750	21.00	537	12583	2.8	68.0	22
1.500	21.00	540	12533	4.9	67.0	39
1.250	21.40	545	12433	9.3	64.0	69
1.125	21.50	549	12383	12.9	61.0	91
1.000	21.50	550	12300	17.6	56.0	116
0.875	21.50	548	12367	22.9	49.0	132
0.750	21.00	537	12517	29.5	41.0	142
0.625	20.40	522	12933	36.5	32.0	135
0.500	19.40	499	13550	43.1	22.0	111
0.375	18.30	471	14300	49.9	13.0	78
0.250	17.10	443	15200	57.3	6.0	42
0.000	16.10	419	16150	67.6	0.0	0

METRIC

Orifice (mm)	Amps	Watts (In)	RPM	Vac (mm H2O)	Flow (l/Sec)	Air Watts
48.000	20.90	536	12630	55.0	32.4	17
40.000	21.00	539	12548	108.0	31.8	34
30.000	21.50	547	12406	287.0	29.4	81
23.000	21.50	549	12350	548.0	24.0	128
19.000	21.00	537	12525	753.0	19.3	142
16.000	20.40	523	12916	920.0	15.3	135
13.000	19.50	501	13488	1,078.0	10.9	113
10.000	18.50	475	14188	1,242.0	6.8	83
6.500	17.20	444	15155	1,446.0	3.0	44
0.000	16.10	419	16150	1,717.0	0.0	0

* Metric data is calculated based on ASTM standards
 Box tests are performed to ASTM F558

WARNING: When using AMETEK vacuum motors in machines that come in contact with foam, liquid (including water), or other foreign substances, the machine must be designed and constructed to prevent those substances from reaching the fan system, motor housing, and electrical components. Ametek motors other than hazardous duty models should not be applied in machines that come in contact with dry chemicals or other volatile materials. Failure to observe these precautions could cause flashing (depending on volatility) or electrical shock which could result in property damage and severe bodily injury, including death in extreme cases. All applications incorporating Ametek motors should be submitted to appropriate organizations or agencies for testing specifically related to the safety of your equipment.